

**IGKIT1 IMPORTANT: UNPACK AND SETUP EACH FRAME INDIVIDUALLY.
SAVE ALL PACKING MATERIAL TO REPACK.**



SET-UP MANUAL

8

7

6

5

4

3

2

1

REVISIONS				
ZONE	REV.	DESCRIPTION	DATE	APPROVED
	A	READY FOR PRODUCTION	8/16/2016	AR
	B	REMOVED 3RD 24400 BAR FROM CENTER FRAME AND REMOVED ALL 3 INCH WELDMENT CORNERS	9/25/2017	AR

OVERVIEW

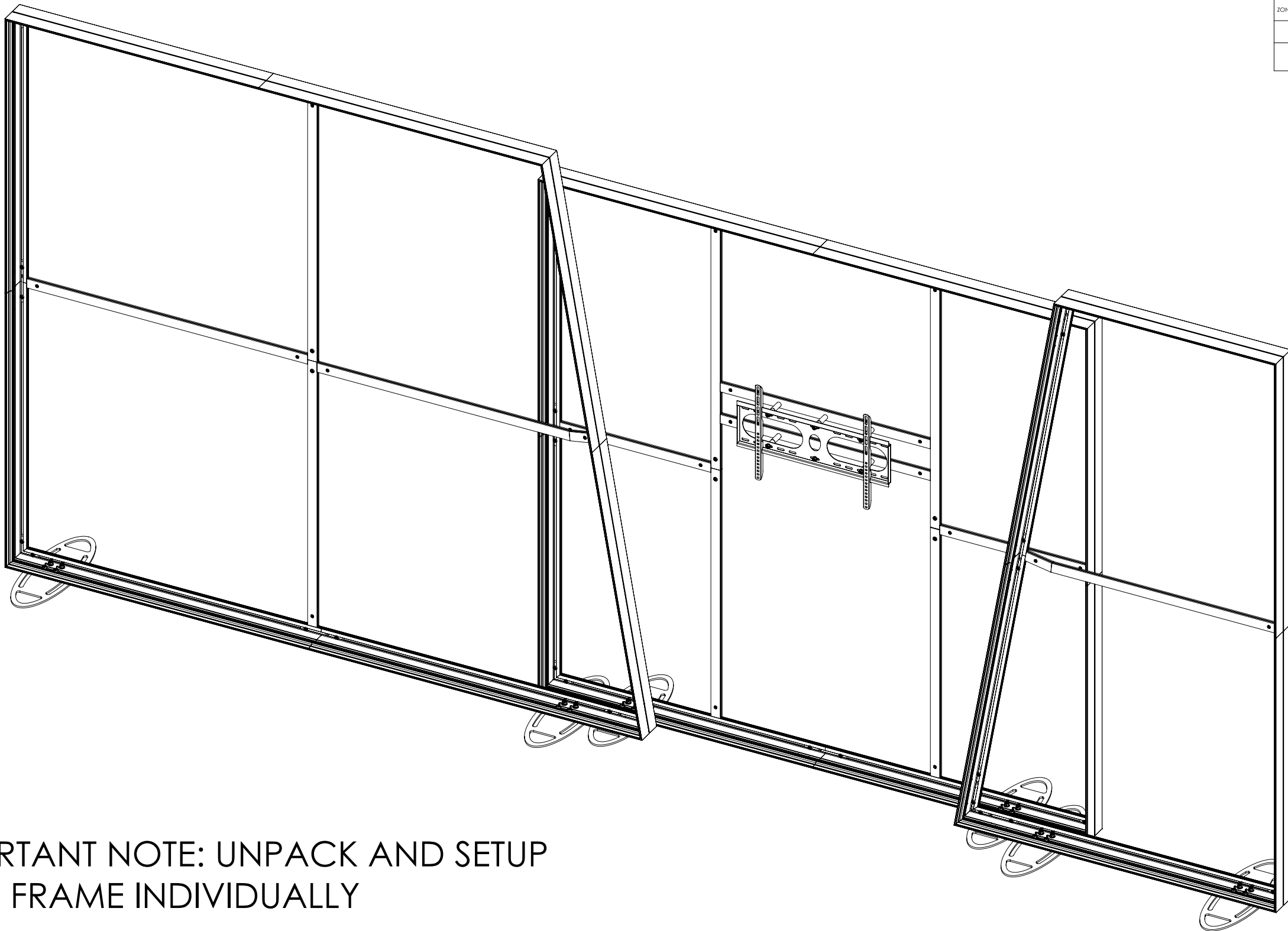

NOTES: UNLESS OTHERWISE SPECIFIED

- 1. ASSEMBLY TIME:
2-1/2 HOURS WITH 2 PEOPLE.

IMPORTANT NOTE: UNPACK AND SETUP EACH FRAME INDIVIDUALLY

ANGLE-TRI-CENTER SINGLE SIDED FRAMES

DRAWN		NAME	DATE	NIEDO GROUP, INC	
CHECKED		ALEX R.	8/16/2016	TITLE:	
ENG APPR.				ANGLE-TRI-CENTER	
MFG APPR.				SINGLE-SIDED FRAME	
Q.A.				SIZE	DWG. NO.
COMMENTS:				D	ATC-216x96SSF-5inC
				SCALE: 1:16	REV B
					SHEET 1 OF 15

PROPRIETARY AND CONFIDENTIAL
THE INFORMATION CONTAINED IN THIS
DRAWING IS THE SOLE PROPERTY OF
NIEDO GROUP. ANY REPRODUCTION
IN PART OR AS A WHOLE WITHOUT
THE WRITTEN PERMISSION OF NIEDO
GROUP IS PROHIBITED.

8

7

6

5

4

3

2

1

D

D

C

C

B

B

A

A

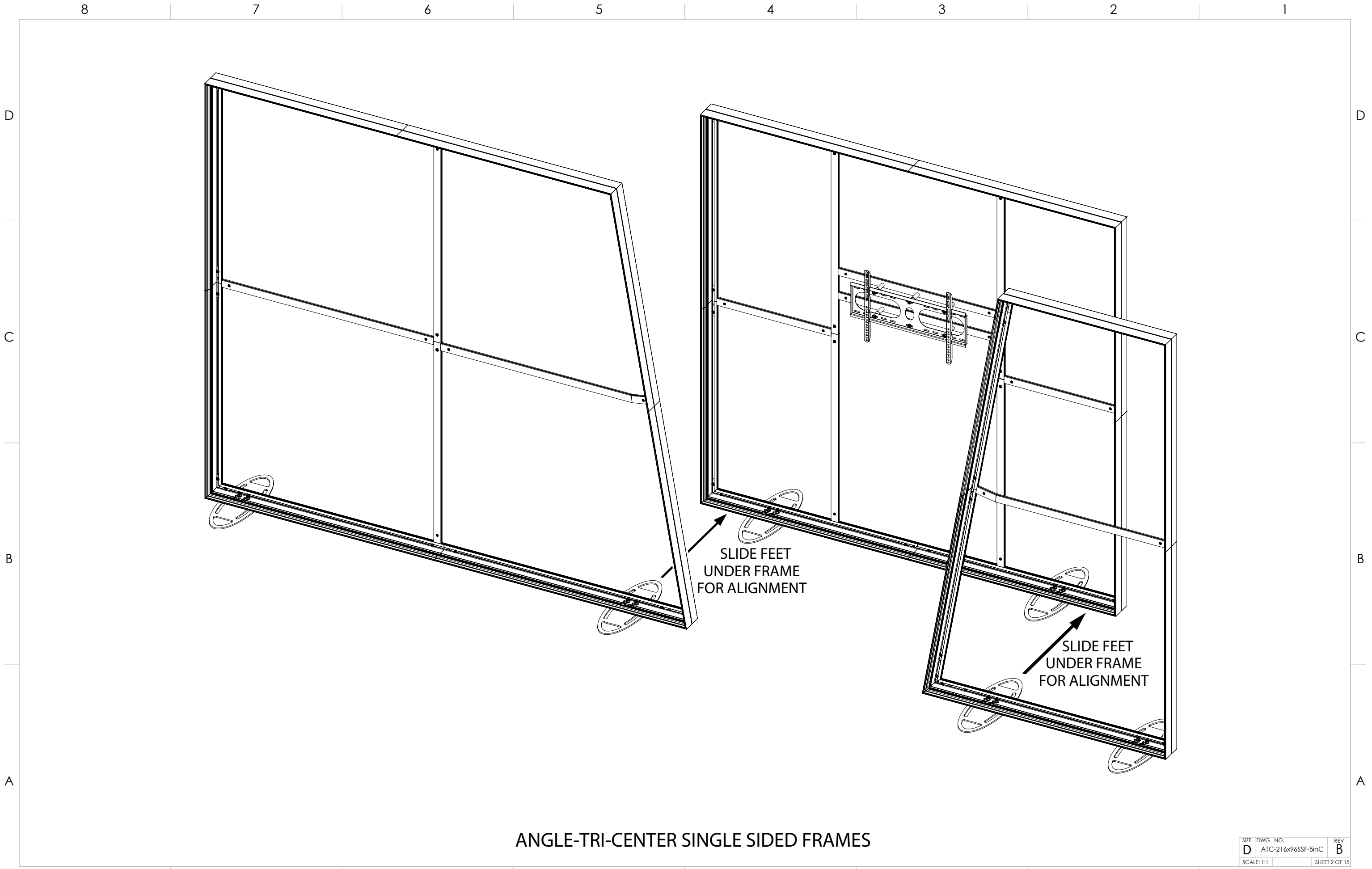

ANGLE-TRI-CENTER SINGLE SIDED FRAMES

SIZE	DWG. NO.	REV
D	ATC-216x96SSF-5inC	B
SCALE: 1:1	SHEET 2 OF 15	

8

7

6

5

4

3

2

1

1. WITH FRAME FLAT ON THE FLOOR ASSEMBLE FRAME SIDES WITH JOINT INSERTS IN OUTSIDE CHANNELS OF FRAME AS SHOWN. TIGHTEN SETSCREWS.

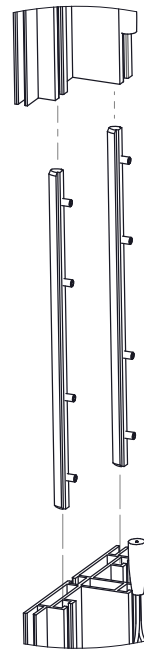

3. ASSEMBLE LONG VERTICAL SUPPORTS BY COUPLING THE 2 SECTIONS USING THE VERTICAL INSERT AND INCLUDED HARDWARE. ASSEMBLE THE VERTICAL SUPPORT TO THE FRAME BY INSERTING THE LOCK MECHANISMS INTO THE CENTER CHANNELS. DO THE SAME FOR THE HORIZONTAL Z4400 SUPPORTS.

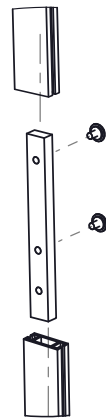

2. ASSEMBLE CORNERS USING CORNER BRACKETS INSERTED INTO OUTSIDE CHANNELS OF FRAME AS SHOWN. FINGER TIGHTEN THUMB SCREWS ONLY.

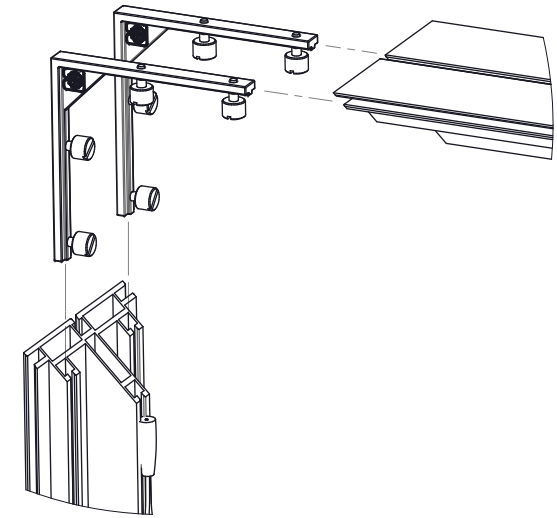

4. ASSEMBLE FEET TO FRAME WITH SCREWS AND HARDWARE PROVIDED. FINGER TIGHTEN WING NUTS.

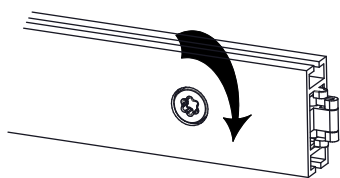
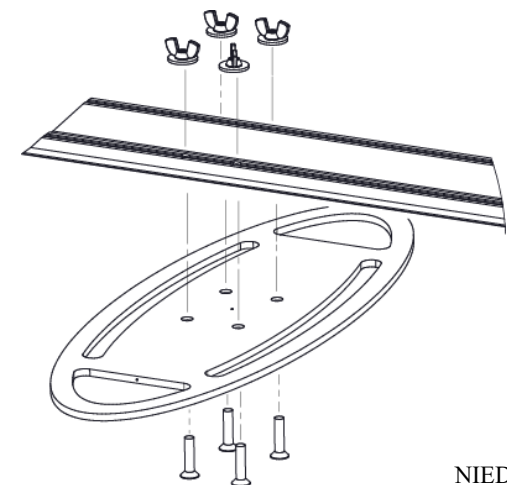

Z4400 EXTRUSION INTERLOCK. TURN TO TIGHTEN, REVERSE TO LOOSEN.

ANGLE RIGHT-SIDE 108in WIDE x 96in H. fFREE-STANDING FRAME

LARGE FRAME ASSEMBLY

NIEDO GROUP, INC	
SIZE DWG. NO.	REV
D	B
Angle R-side	108inWx96inH SSF
SCALE: 1:12	SHEET 1 OF 5

8

7

6

5

4

3

2

1

8

7

6

5

4

3

2

1

1. WITH FRAME FLAT ON THE FLOOR ASSEMBLE FRAME SIDES WITH JOINT INSERTS IN OUTSIDE CHANNELS OF FRAME AS SHOWN. TIGHTEN SETSCREWS.

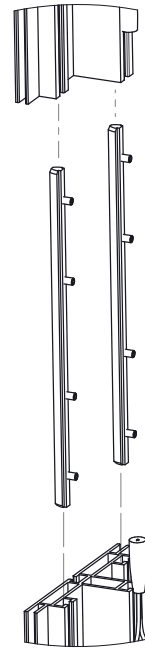

2. ASSEMBLE CORNERS USING CORNER BRACKETS INSERTED INTO OUTSIDE CHANNELS OF FRAME AS SHOWN. FINGER TIGHTEN THUMB SCREWS ONLY.

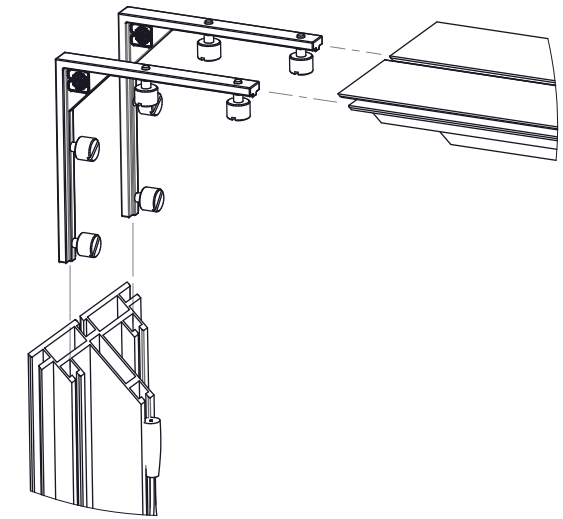

3. ASSEMBLE HORIZONTAL SUPPORT OF THE FRAME BY INSERTING THE LOCK MECHANISMS INTO THE CENTER CHANNELS OF FRAME.

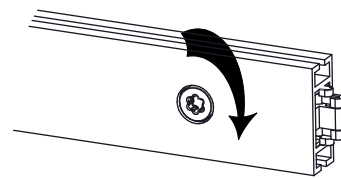

Z4400 EXTRUSION INTERLOCK. TURN TO TIGHTEN, REVERSE TO LOOSEN.

4. ASSEMBLE FEET TO FRAME WITH SCREWS AND HARDWARE PROVIDED. FINGER TIGHTEN WING NUTS.

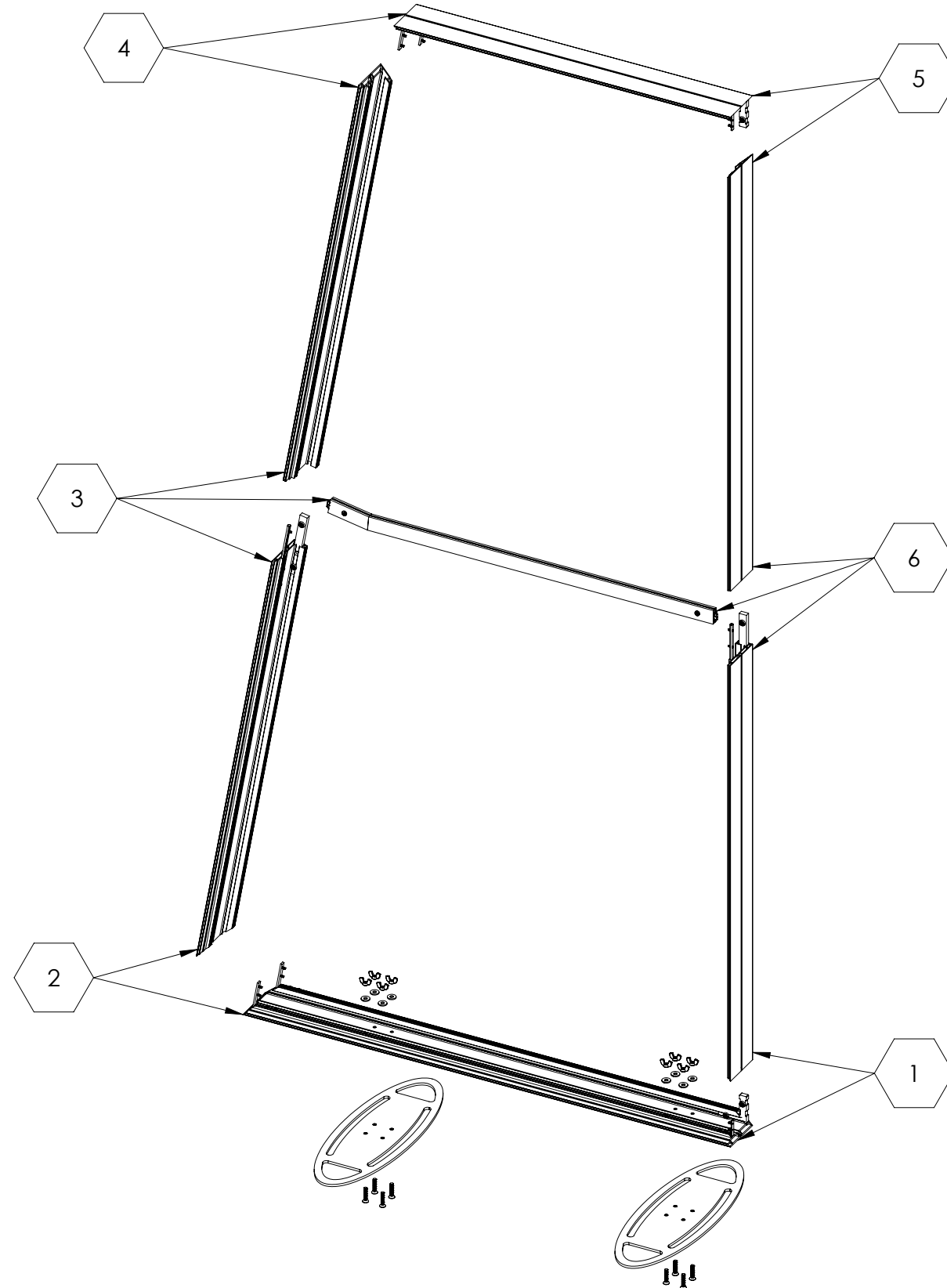
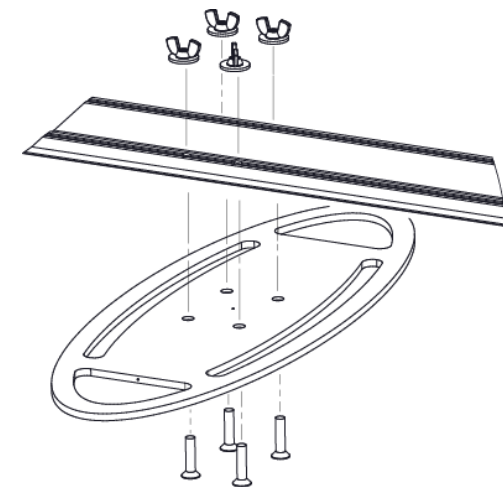

ANGLE LEFT-SIDE 54.60in WIDE x 96in H. SINGLE-SIDED FRAME

SMALL FRAME ASSEMBLY

SIZE DWG. NO.

NIEDO GROUP, INC

SIZE	DWG. NO.	REV
D	Angle L-side 54.60inWx96inH SSF	B
SCALE: 1:12/WEIGHT:		SHEET 1 OF 4

8

7

6

5

4

3

2

1

93" x 90" FREESTANDING IGNITER LIGHTBOX IG93X90-TV

**PLEASE REFER TO LAST PAGE OF
MANUAL FOR SEG INSTRUCTIONS**

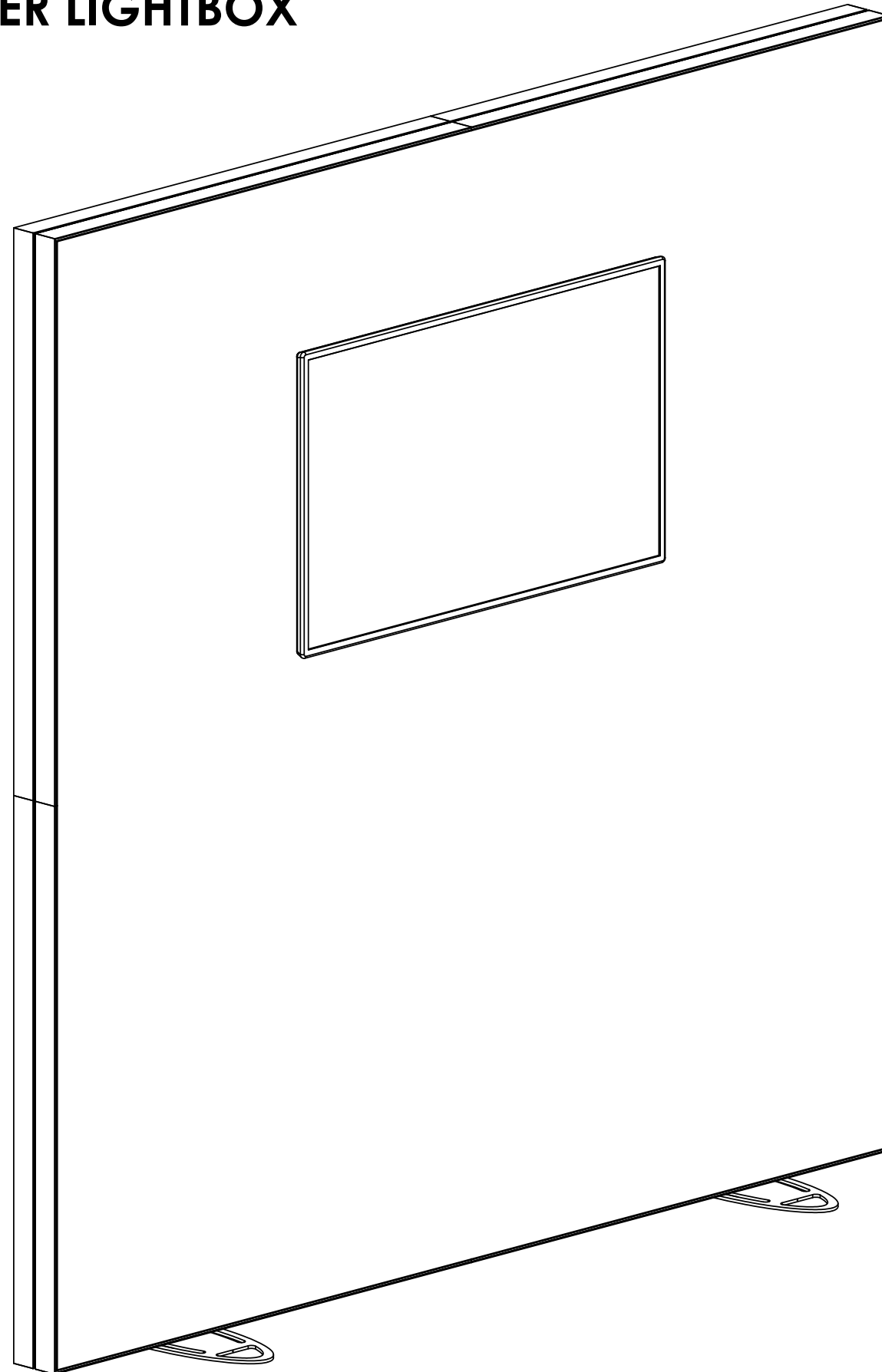

**FRONT VIEW
WITH GRAPHIC & MONITOR**

SET-UP MANUAL



FINISH:		THIRD ANGLE		PROPERTY	
MATERIAL:		DIMENSIONS ARE IN MILLIMETERS		THIS DOCUMENT AND DATA DISCLOSED HEREIN OR HEREWITH IS NOT TO BE REPRODUCED, USED, OR DISCLOSED IN WHOLE OR IN PART TO ANYONE WITHOUT PERMISSION OF NIEDO GROUP, INC.	
TOLERANCES UNLESS OTHERWISE SPECIFIED:		NIEDO GROUP, INC.		5465 SW WESTERN AVE. BEAVERTON, OR 97005	
SCALE: NA		DO NOT SCALE DRAWING		SHEET 1	
REV B		DWG. NO.		REV -01	

93" x 90" FREESTANDING IGNITER LIGHTBOX IG93X90-TV

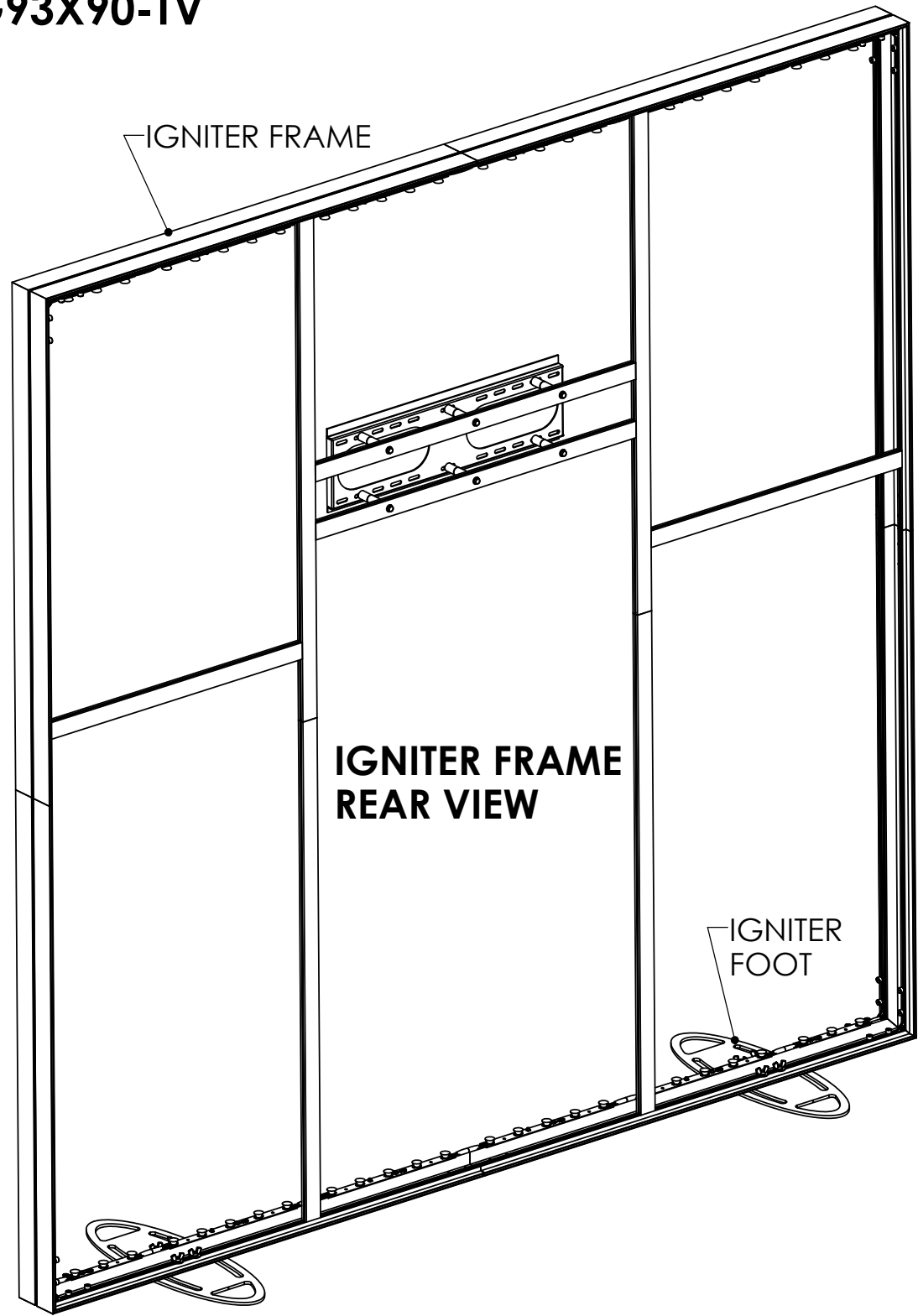

NOTE: HORIZONTAL AND VERTICAL SUPPORTS MOUNT CENTER FRAME CHANNEL

GENERAL NOTES & DETAIL

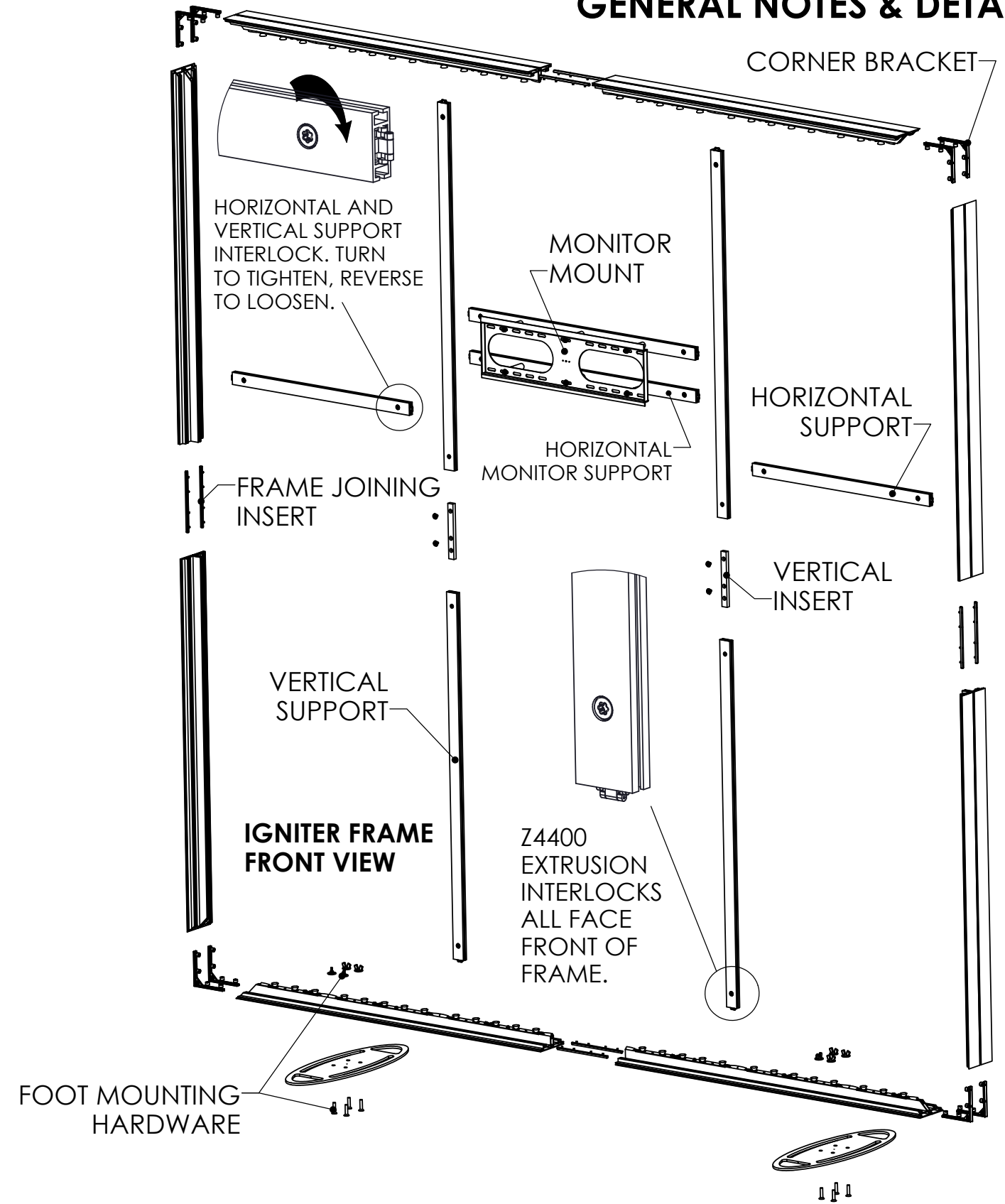

FINISH:	THIRD ANGLE PROJECTION	PROPERTY: THIS DOCUMENT AND DATA DISCLOSED HEREIN OR HEREBY IS NOT TO BE REPRODUCED, USED, OR DISCLOSED IN WHOLE OR IN PART TO ANYONE WITHOUT PERMISSION OF NIEDO GROUP, INC.
MATERIAL:		
DIMENSIONS ARE IN MILLIMETERS	NIEDO GROUP, INC. 5465 SW WESTERN AVE. BEAVERTON, OR 97005	
TOLERANCES UNLESS OTHERWISE SPECIFIED	FREESTANDING IGNITER LIGHTBOX SETUP INSTRUCTION	
SHEET B	DWG. NO.	REV. -01
SCALE: NA	DO NOT SCALE DRAWING	SHEET 1

93" x 90" FREESTANDING IGNITER LIGHTBOX IG93X90-TV

FRAME ASSEMBLY DETAILS

1. WITH FRAME FLAT ON THE FLOOR ASSEMBLE FRAME SIDES WITH JOINT INSERTS IN OUTSIDE CHANNELS OF FRAME AS SHOWN. TIGHTEN SETSCREWS.

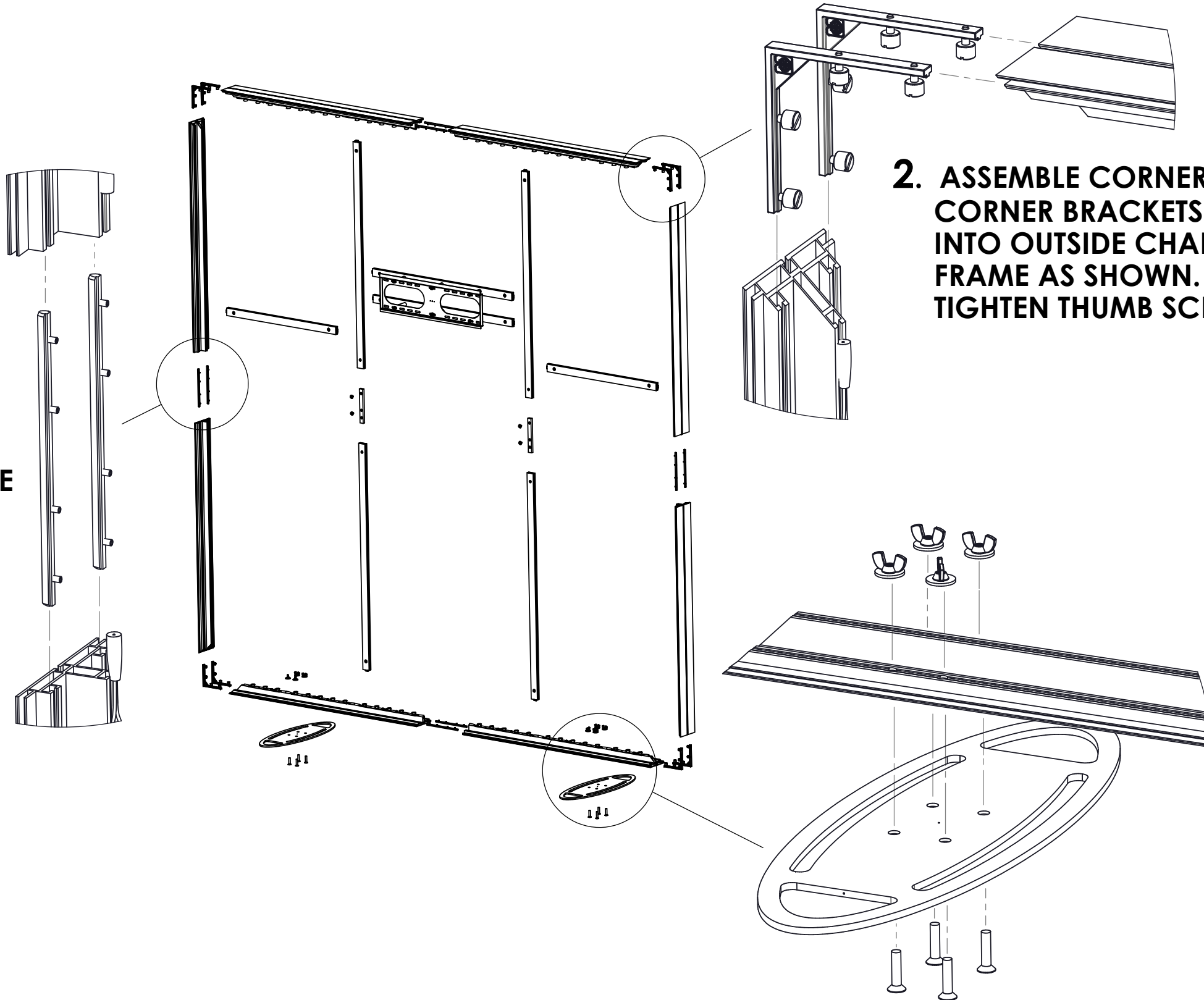

2. ASSEMBLE CORNERS USING CORNER BRACKETS INSERTED INTO OUTSIDE CHANNELS OF FRAME AS SHOWN. FINGER TIGHTEN THUMB SCREWS ONLY.

3. ASSEMBLE FEET TO FRAME WITH SCREWS AND HARDWARE PROVIDED. FINGER TIGHTEN WING NUTS. STAND FRAME UP FOR MONITOR MOUNT ATTACHMENT.

FINISH:	THIRD ANGLE PROJECTION	PROPERTY: THIS DOCUMENT AND DATA CONTAINED HEREIN OR HEREBY IS NOT TO BE REPRODUCED, USED, OR DISCLOSED IN WHOLE OR IN PART TO ANYONE WITHOUT PERMISSION OF NIEDO GROUP, INC.
MATERIAL:		
DIMENSIONS ARE IN MILLIMETERS	NIEDO GROUP, INC. 5465 SW WESTERN AVE. BEAVERTON, OR 97005	
TOLERANCES UNLESS OTHERWISE SPECIFIED	96" x 96" FREESTANDING IGNITER LIGHTBOX SETUP INSTRUCTION	
REV: B	DWG. NO.:	REV: -01
SCALE: NA	DO NOT SCALE DRAWING	SHEET 1

MONITOR MOUNT ATTACHMENT DETAIL

4. ASSEMBLE LONG VERTICAL SUPPORTS BY COUPLING THE 2 SECTIONS USING THE VERTICAL INSERT AND INCLUDED HARDWARE.

NOTE: INTERLOCK MECHANISMS ON Z4400 EXTRUSION SUPPORTS FACE FRONT FOR CONVENIENT ADJUSTMENT. SEE PAGE 2 FRONT VIEW DETAIL.

5. ASSEMBLE THE COMPLETE VERTICAL SUPPORT TO THE FRAME BY INSERTING THE TOP AND BOTTOM INTERLOCK MECHANISMS INTO THE TOP AND BOTTOM FRAME CENTER CHANNELS.

DETAIL A

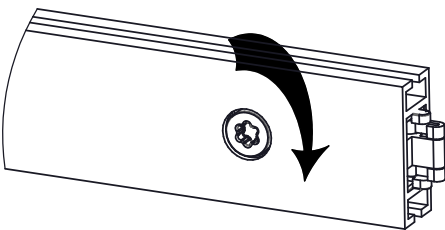

Z4400 EXTRUSION INTERLOCK. TURN TO TIGHTEN, REVERSE TO LOOSEN.

6. INSERT MONITOR ASSEMBLY BETWEEN VERTICAL SUPPORTS WITH INTERLOCKS PUSHED INTO THE VERTICAL SUPPORT SIDE CHANNELS. TIGHTEN INTERLOCK MECHANISMS AS IN DETAIL A.

FRAME REAR VIEW

7. LOOSEN THE SETSCREWS FOR THE TOP FRAME JOINING INSERTS ENOUGH TO ALLOW THE TOP FRAME TO BE SPREAD SLIGHTLY APART.

8. ASSEMBLE HORIZONTAL SUPPORTS TO FRAME BY INSERTING INTERLOCKS INTO CENTER CHANNEL OF FRAME AND SIDE CHANNELS OF LONG VERTICAL SUPPORTS.

AND SIDE CHANNELS OF LONG VERTICAL SUPPORTS.

BE CERTAIN THAT ALL SET SCREWS ARE TIGHTENED AND THAT INTERLOCKS ARE FULLY ENGAGED AND SECURE.

FINISH:	THIRD ANGLE PROJECTION	PROPRIETARY THIS DOCUMENT AND DATA DISCLOSED HEREIN OR HEREAFTER IS NOT TO BE REPRODUCED, USED, OR DISCLOSED IN WHOLE OR IN PART TO ANYONE WITHOUT PERMISSION OF NIEDO GROUP, INC.
MATERIAL:	NIEDO GROUP, INC. 5465 SW WESTERN AVE. BEAVERTON, OR 97005	
DIMENSIONS ARE IN MILLIMETERS	96" x 96" FREESTANDING IGNITER LIGHTBOX SETUP INSTRUCTION	
TOLERANCES UNLESS OTHERWISE SPECIFIED	REV. B	REV. -01
SCALE: NA	DO NOT SCALE DRAWING	SHEET 1

Silicone Edge Graphics (SEG)

Installation Instructions into hardware

What are Silicone Edge Graphics (SEG)?

SEG are dye-sublimation fabric graphics with silicone strips sewn along the underside of the fabric's edge. SEG frames have grooves along their perimeter designed to snugly hold the silicone strips so the fabric can be stretched across the frame for a drum-tight fit.



We recommend laying the frame on the floor, then draping the fabric graphic on top.

The following procedure ensures the silicone edge will be placed evenly over the entire frame and NOT STRETCH or GROW at the corners. Once all the edges have been secured, you should have a taut fit with a smooth flat finish.

1: With Clean Hands,

Press SEG silicone edge first, into the corners of the frame.

INCORRECT WAY

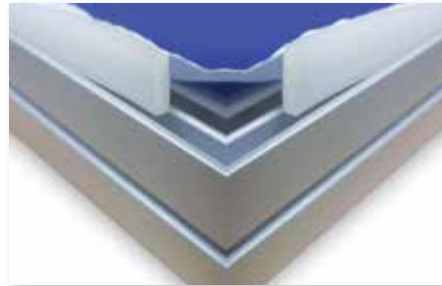

CORRECT WAY

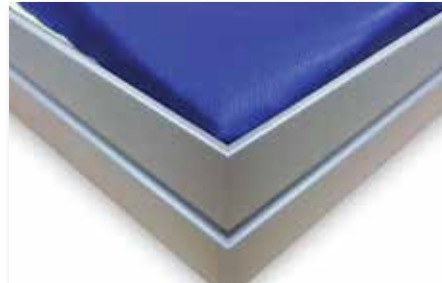

2: Working in Centers.

Go back and press the silicone edge into the center - on each side of the frame.

EXAMPLE: A 20"x20" fabric/frame would be pressed in 8 locations.

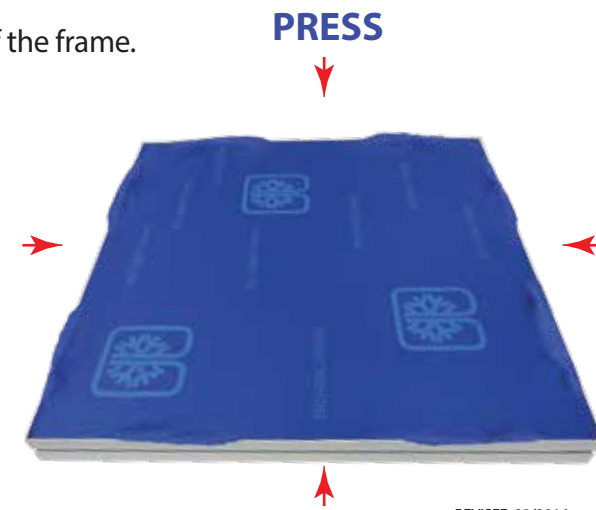

REVISED 03/2016

Cont'd.

3: Working in Centers again,

Go back and press the silicone edge once again on each side previous center, on all 4 sides.

Repeat this process, (WORKING IN CENTERS) until the SEG fabric's edge is pressed approximately every 6 inches apart.

EXAMPLE: A 8' x 8' frame (using this procedure) will have been pressed/tucked 15 times (not including corners) on each side of the frame.

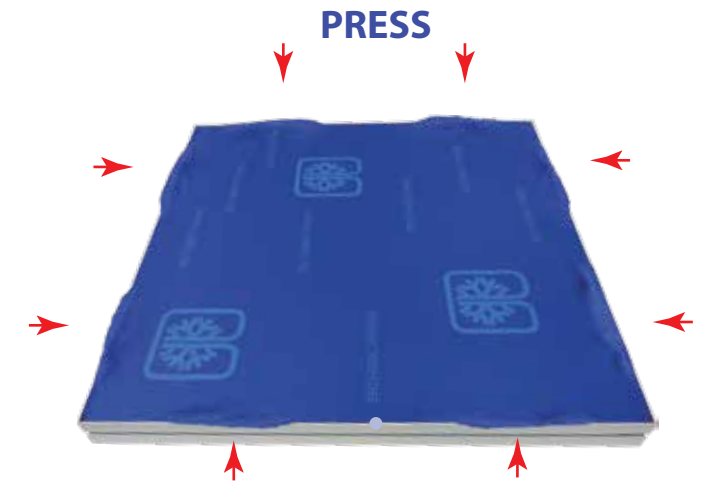
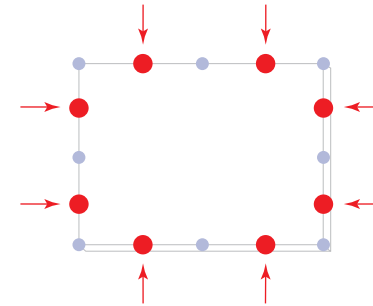

4: After all has been pressed into your frame using

this procedure, lightly tap your forefinger to smooth fabric between the tucks.



CARE INSTRUCTIONS

Due to the fine quality, smoothness and weave of the fabric, great care must be taken to extend the life of your SEG fabric graphics.

We recommend very loosely folding your graphic, making sure there are no hard creases or folds or that the fabric doesn't catch on sharp objects.

Store in a clean bag.
A plastic bag or pillow case is ideal.
Graphics can also be spot cleaned with a damp cloth.

To wash entire graphic, use a commercial size front loading washing machine on gentle cycle with cool water. Do NOT dry clean.

You can also gently iron the back side using the Polyester setting of your iron.



REVISED 04/2016